

Tous droits strictement réservés. Reproduction ou communication à des tiers interdite sous quelque forme que ce soit sans autorisation écrite du propriétaire. Propriété de c FCI. Droits de reproduction FCI.

All rights strictly reserved. Reproduction or issue to third parties in any form whatever is not permitted without written authority from the proprietor. Property of FCI. Copyright FCI.

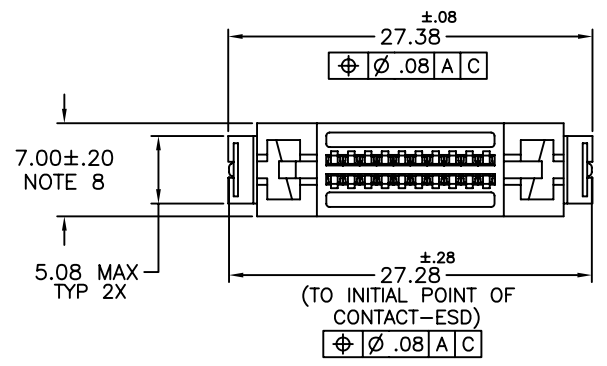

PRODUCT NO.  
SEE TABLE

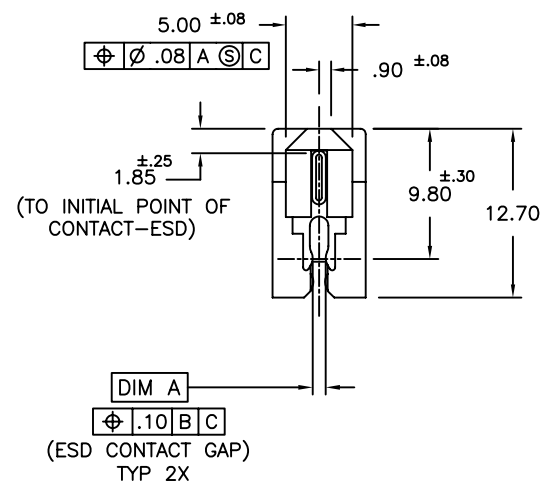
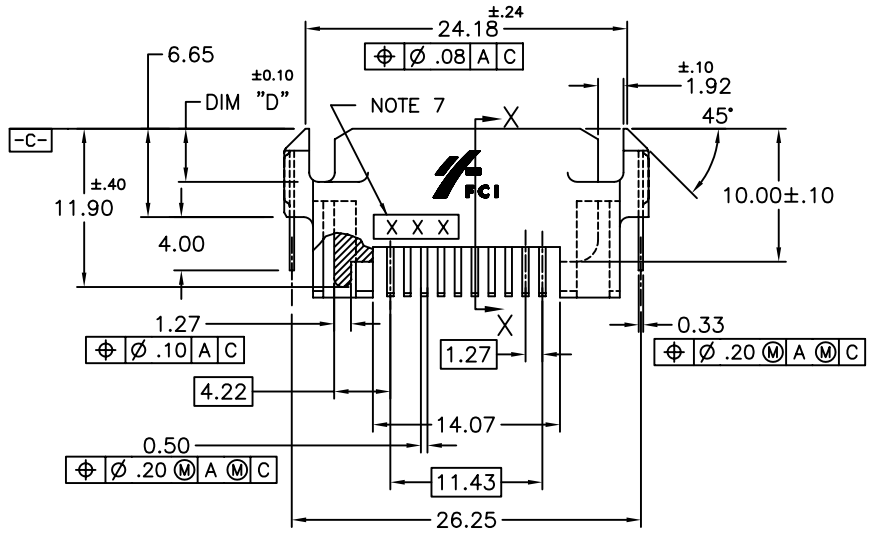
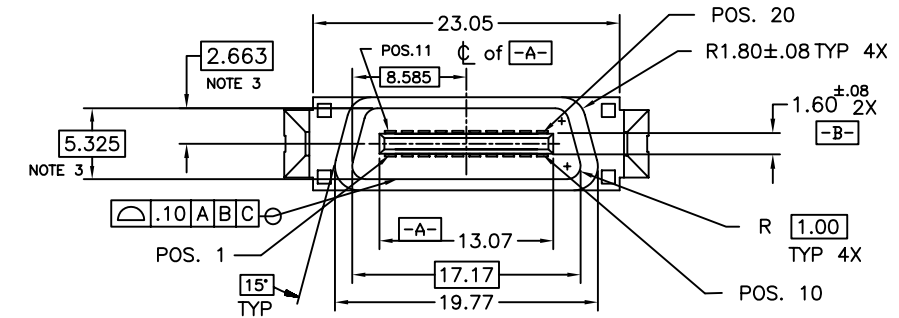

CONFIDENTIAL

mat'l. code				tolerances unless otherwise specified		CUSTOMER COPY		www.fciconnect.com				
ltr	ecn no	dr	date	linear	.X ±.3	projection		title				
G	S10131	GLL	11/12/01		.XX ±.13			SCA2 PLUG CONNECTOR STRADDLE MOUNT				
H	S03-0049	GLL	4/3/03	angles	.XXX ±.051		product family	SCA-2	code			
J	S04-0029	GLL	3/2/04		0' ±2'			size	dwg no	-		
K	S04-0058	GLL	3/30/04	dr	TANGWEI	9/25/98	scale	A	72547			
L	S04-0246	GLL	11/18/04	enr	GL L00	9/25/98				1:1	sheet	1 of 3
M	S05-0051	GLL	2/23/05	chr	GL L00	9/25/98						
				appd	JOEY NG	9/25/98						
sheet index	revision sheet	M	M	M								
		1	2	3								

cage code  
22526  
STATUS: Released

ACAD

PDM: Rev:M

Printed: Feb 01, 2007

Tous droits strictement réservés. Reproduction ou communication à des tiers interdite sous quelque forme que ce soit sans autorisation écrite du propriétaire. Propriété de c FCI. Droits de reproduction FCI.

All rights strictly reserved. Reproduction or issue to third parties in any form whatever is not permitted without written authority from the proprietor. Property of FCI. Copyright FCI.

PRODUCT NO.  
SEE TABLE

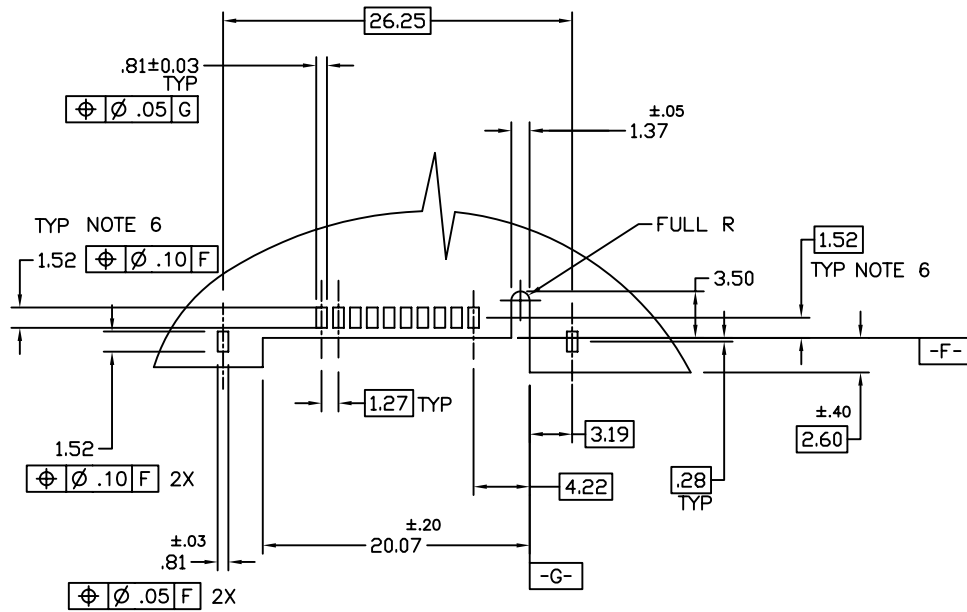

RECOMMENDED PC BOARD MOUNTING DIMENSIONS

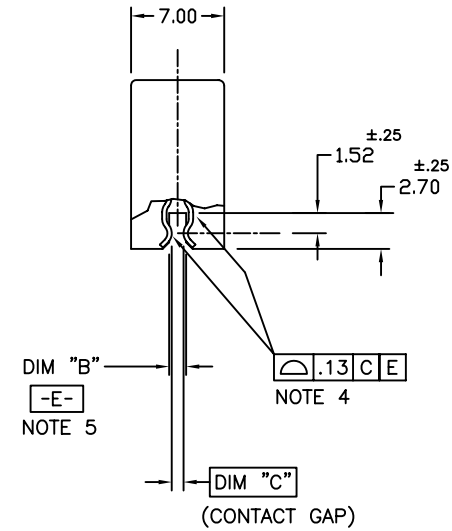

SECTION X-X

CONFIDENTIAL

mat'l. code				tolerances unless otherwise specified			CUSTOMER COPY		 www.fciconnect.com	
ltr	ecn no	dr	date	linear	.X ±.3		projection	title <b>SCA2 PLUG CONNECTOR STRADDLE MOUNT</b>		
M					.XX ±.13					
				angles	.XXX ±.051			product family SCA-2 code - size dwg no 72547 sheet 2 of 3		
					0° ±2'					
				dr	TANGWEI	9/25/98	← MM → scale 1:1	A		
				enr	GL LOO	9/25/98				
				chr	GL LOO	9/25/98				
				appd	JOEY NG	9/25/98				
sheet index	revision sheet		1							

cage code  
22526

ACAD

PDM: Rev:M

STATUS: Released

Printed: Feb 01, 2007

Tous droits strictement réservés. Reproduction ou communication à des tiers interdite sous quelque forme que ce soit sans autorisation écrite du propriétaire. Propriété de c FCI. Droits de reproduction FCI.



All rights strictly reserved. Reproduction or issue to third parties in any form whatever is not permitted without written authority from the proprietor. Property of FCI. Copyright FCI.

PRODUCT NO.	NO. OF POS.	RECOMMENDED PCB THICKNESS	DIM. A	DIM. B	DIM. C	DIM. D	PLATING SPEC	PRODUCT NO.	PLATING SPEC	PRODUCT NO.	PLATING SPEC
72547-001	20	1.19	.970	1.32	0.88	4.00	NOTE 2	72547-001LF	NOTE 16	72547-201LF	NOTE 12
72547-001S											
72547-002											
72547-002S											
72547-003											
72547-003S	20	1.57	1.520	1.83	1.44	5.00	NOTE 10	72547-003LF		72547-203LF	
72547-103S											
72547-004	20	1.57	1.520	1.83	1.44	4.00	NOTE 10	---		72547-204LF	
72547-004S											

NOTES:

- HOUSING : LCP, UL94V-0 RATED, COLOR: BLACK  
CONTACTS: PHOSPHOR BRONZE  
ESD CONTACT: PHOSPHOR BRONZE
- PLATING: CONTACT: 0,76µm (30µ") MIN GXT IN CONTACT AREA, 2,54µm (100µ") MIN TIN-LEAD ON P.C. BOARD LEG, 1,27µm (50µ") MIN. NICKEL UNDERPLATE OVER ENTIRE TERMINAL  
ESD CONTACT: 2,54 µm (100µ") MIN TIN-LEAD PLATING WITH 1,27µm (50µ") MIN. NICKEL UNDERPLATE
- MEASURED AT THE FLOOR OF THE CAVITY MEASURED 6mm FROM DATUM  $\square-Z$  .
- APPLIES TO ALL SURFACES OF CONTACT TAILS
- MAXIMUM BOARD THICKNESS THAT CONNECTOR CAN ACCOMODATE IS DEFINED BY "B" DIM.
- THESE DIMENSIONS RESULT IN THE CONTACT RESTING IN CENTER OF PAD WIDTH. THESE DIMENSIONS ARE SUBJECT TO CHANGE DEPENDING ON CUSTOMERS MANUFACTURING PREFERENCES IN PROCESS, SOLDER PLACEMENT AND REFLOW.
- DATE CODE IN THIS AREA.
- MEASUREMENT MADE AT THE CENTER OF PART MAY BE AS LOW AS 6.55. DESIGN TO BE MADE TO ACHIEVE THE NOMINAL DIMENSION ACROSS THE ENTIRE PART.
- DISTANCE MEASURED ACROSS CONTACT MATING SURFACES ALONG EFFECTIVE MATING AREA AND CONTACT MUST BE ABOVE PLASTIC ALONG EFFECTIVE MATING AREA.
- PLATING: CONTACT: 0,76µm (30µ") MIN GOLD IN CONTACT AREA, 2,54µm (100µ") MIN TIN-LEAD ON P.C. BOARD LEG, 1,27µm (50µ") MIN. NICKEL UNDERPLATE OVER ENTIRE TERMINAL  
ESD CONTACT: 2,54 µm (100µ") MIN TIN-LEAD PLATING WITH 1,27µm (50µ") MIN. NICKEL UNDERPLATE
- PART NUMBERS ENDING IN -0xx or -0xxS or -1xxS ARE MANUFACTURED WITH BRIGHT FINISH TIN-LEAD PLATING IN P.C. BOARD LEG AREA.
- PLATING: CONTACT: 0,76µm (30µ") MIN GOLD IN CONTACT AREA, 2,54µm (100µ") - 5,08µm (200µ") TIN ON P.C. BOARD LEG, 1,27µm (50µ") MIN. NICKEL UNDERPLATE OVER ENTIRE TERMINAL  
ESD CONTACT: 2,54 µm (100µ") -5,08µm (200µ") TIN PLATING WITH 1,27µm (50µ") NICKEL UNDERPLATE
- THE HOUSING WILL WITHSTAND EXPOSURE TO 260°C PEAK TEMPERATURE FOR 10 SECONDS IN A CONVECTION, INFRA-RED OR VAPOR PHASE REFLOW OVEN.
- THIS PRODUCT MEETS EUROPEAN UNION DIRECTIVES AND OTHER COUNTRY REGULATIONS AS DESCRIBED IN GS-22-008.
- PART NUMBERS ENDING IN "LF" MEANS FOR NOTE 14 LEAD FREE IDENTIFICATION. P/N XXXXX-2XXLF IS EQUIVALENT TO PREVIOUS P/N XXXXX-2XX .
- PLATING: CONTACT: 0,76µm (30µ") MIN GXT IN CONTACT AREA, 2,54µm (100µ") - 5,08µm (200µ") TIN ON P.C. BOARD LEG, 1,27µm (50µ") MIN. NICKEL UNDERPLATE OVER ENTIRE TERMINAL  
ESD CONTACT: 2,54 µm (100µ") -5,08µm (200µ") TIN PLATING WITH 1,27µm (50µ") NICKEL UNDERPLATE



CONFIDENTIAL

mat'l. code				tolerances unless otherwise specified				CUSTOMER COPY		www.fciconnect.com			
ltr	ecn no	dr	date	linear	.X ±.3			projection		title			
M					.XX ±.13					SCA2 PLUG CONNECTOR			
					.XXX ±.051					STRADDLE MOUNT			
				angles	0° ±2'			MM scale 1:1	product family		code		
				dr	TANGWEI	9/25/98	SCA-2		-				
				engr	GL LOO	9/25/98	size		-				
				chr	GL LOO	9/25/98	dwg no		-				
				appd	JOEY NG	9/25/98	72547		sheet 3 of 3				
sheet index	revision sheet		1										